

YSI MODEL 31A CONDUCTANCE BRIDGE

INSTRUCTIONS

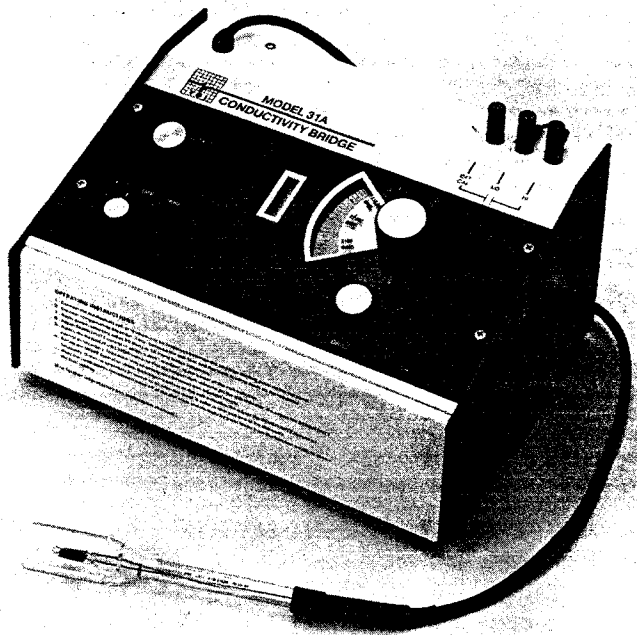

GENERAL DESCRIPTION

The YSI Model 31A is a laboratory instrument designed for precise measurement of both electrical resistance and conductance of solutions.

A manually balanced AC bridge contains two adjustable legs, a voltage divider range switch and a precision potentiometer which is mechanically connected to a calibrated dial. The bridge output is amplified and applied to control a null indicator. As the bridge approaches null, a rectangular "shadow" appears on the indicator. In operation, the sensitivity control, range switch, and drive control are adjusted until a maximum "shadow" appears on the indicator. A partial dimming of indicator segments may be considered a part of this shadow. Resistance or conductance is then read from the dial.

The bridge can be operated at either 1 KHz or at line frequency (normally 50 or 60 Hz). When measuring high conductances, the bridge is more readily nulled at 1 KHz. Lower conductances should show the same reading at either frequency; that both frequencies provide a null at the same value for a given solution provides a useful check of conductivity cell condition. The 1 KHz frequency cannot be used with solutions of extremely low conductance, such as distilled water, because a sharp null point will not appear. In general, the frequency used for measurement of a given solution should be the one providing the sharpest null point.

SPECIFICATIONS

Range: 0.2 ohms to 2.5 megohms (Resistance)
0.2 micromhos to 2.5 mhos (Conductance)

Resolution & Accuracy:

Both resolution and accuracy are limited by the operator's skill and judgement in obtaining the null and interpolating between the dial-scale divisions.

Dial Calibration Accuracy:

Resistance: $\pm 1\%$ of reading from 2.0 to 25 on the scale.

Conductance: $\pm 1\%$ of reading from 2.0 to 25 on the scale

Conductivity: The indicated reading $\pm 1\%$ is within $\pm 0.5\%$ of the reading obtained with the same cell and solution with YSI Metrology's reference instruments.

Resolution: Visual Interpolation

The dial scale is labelled from .2 to 25 and graduated as follows:

Scale Labels	Graduations	Resolution of Scale
.2 to 5	.1	.4% of full scale
5 to 15	.2	.8 " " "
15 to 25	.5	2.0 " " "

Resolution: Substitution of Calibrated Resistor to Measure the Null ± 1 turn of the wirewound bridge-balance potentiometer.

Scale Labels	% of Reading	% of Full Scale
.2	9.764	.0078
1	1.118	.0447
2	0.576	.0461
3	0.409	.0491
4	0.327	.0523
5	0.279	.0558
6	0.247	.0593
7	0.224	.0627
8	0.207	.0662
9	0.194	.0698
10	0.184	.0736
15	0.153	.0918
20	0.137	.1096
25	0.128	.1280

Indicator: 10 Segment LED Bar-graph null indicator.

Bridge Supply: Line frequency or 1 KHz, $\pm 10\%$, sine wave selected by front panel switch.

Ambient Range: 0 to 50 degrees C at rated accuracy

Power Requirements:

95 to 125 VAC, 50-60 Hz, 0.125 amp, 10 watts.

(Instruments also are available for 230 volts, operable from 190-250 VAC, 50-60 Hz, 0.062 amp, 10 watts).

FUNDAMENTALS

The Systeme International d'Unites (S.I.) unit siemens is identical to the more familiar mho, but the dimensions of the cell constant must also be considered when converting observed conductance to conductivity. It has been an unfortunate but common practice to drop the dimensional unit when expressing cell constants. For example, in U.S. practice (cgs metric) we refer to a cell constant of 1.0 when we mean $K = 1.0/\text{cm}$. In the S.I. system (mks metric) a cell constant of 1.0 means 1.0/m, which is equal to 0.01/cm in cgs units.

The Model 31A can be considered to be direct reading in electrolytic conductivity units when working in S.I. and using a conductivity cell with a constant of 1/m (.01/cm) or in the cgs system when using a conductivity cell with a constant of 1/cm (100/m). However, cells having other constants may also be used, and it should be noted that, regardless of manufacture, the electrical properties of the cell will not be absolutely constant over the wide overall range afforded by this instrument. For maximum accuracy, cell constants should be determined experimentally, using appropriate reference materials having conductivities in the approximate range of interest. (YSI cells are calibrated to an absolute accuracy of $\pm 1\%$ using a reference solution of 0.01 mmol/l KCl; see Cell Calibration.)

The instrument will very accurately display the conductance presented to its input terminals. Conductivity is then determined by multiplying the displayed conductance by the cell constant (being careful to observe the dimensional units of the constant).

The standard measure of electrolytic conductivity is specific conductance; its unit has no name, but is usually expressed by the letter k and defined as the reciprocal of the resistance in ohms of a 1 cm cube of liquid at a specified temperature. The units of conductivity are siemens/meter or mhos/cm. Siemens/meter = mhos/100 cm. (Siemens/cm is also electrically correct, but prohibited by S.I. Its use should probably be avoided to prevent confusion with the S.I. siemens/meter.)

The observed conductance of a solution depends inversely on the distance d between the electrodes and directly upon their area A :

$$1/R = k A/d$$

For a given cell with fixed electrodes, the ratio d/A is a constant. This ratio is called the cell constant K . (The electrical value of the constant will vary slightly with electrolyte concentration--see "Conductivity Cells.") Therefore:

$$k = K/R$$

The standard measure of electrolyte resistivity is specific resistance, the reciprocal of the above relationship. The units of resistivity are ohm-meters or ohm-centimeters.

The observed resistance of a solution varies directly with the distance d between the electrodes and inversely with their Area A :

$$R = \rho d/A$$

where ρ is the constant of proportionality of specific resistance. Therefore:

$$\rho = R/K$$

Conductivity is determined by multiplying the measured solution conductance by the cell constant. Resistivity is determined by dividing the measured solution resistance by the cell constant. In either case, care should be taken to observe the dimensions of the cell constant (for SI or cgs units).

For an observed conductance of 100 microsiemens (100 micromhos) and a cell constant $K = 10/\text{m}$:

$$k = 100 \text{ microS} \times 10/\text{m} = 1 \text{ milliS/m}$$

In c.g.s. units the cell constant $K = 10/\text{m}$ becomes $K = 0.1/\text{cm}$ and the same conductivity is expressed:

$$k = 100 \text{ micromhos} \times 0.1/\text{cm} = 10 \text{ micromhos/cm}$$

INSTRUMENT OPERATION

CONTROLS

Instruments are equipped with the following controls:

1. Function Switch: controls power to instrument and selects Line frequency or 1KHz bridge frequency.
2. Sensitivity: controls effective sensitivity of null amplifier. Set at minimum (counterclockwise) when determining range of resistance or conductance. Adjust toward maximum (clockwise) when making measurements.
3. Range Switch: selects proper multiplier for direct measurement of resistance or conductance.
4. Drive: drives the calibrated dial and the null potentiometer.

MAKING CONDUCTANCE MEASUREMENTS

When you have chosen a cell appropriate to your measurement circumstances (see "Conductivity Cell Selection"), use the following procedures to make conductance measurements:

1. Connect the instrument to a power source, 117 VAC or 230 VAC depending on the instrument model.
2. Set the Function Switch to the LINE position.
3. Place the conductivity cell in the unknown solution. The electrodes must be submerged and the electrode chamber must contain trapped air. Tap the cell to remove any bubbles and dip it two or three times to assure proper wetting. If you are using a flow through cell, be sure it is completely full.

NOTE: The Solution being measured must not be grounded if the instrument is grounded. The instrument may be operated ungrounded by use of a line cord adaptor with the pigtail ungrounded.

4. Connect the cell leads to the HI and LO terminals.

Null the bridge as follows:

5. Rotate the Sensitivity control to its full counterclockwise position.
6. Use the Drive knob to set the dial to 1.0.
7. Rotate the Range Switch to the conductivity range which gives the maximum shadow length on the indicator. NOTE: "Shadow" means the center area of the display which is not lighted, or is dimmed.

8. Adjust the Drive control for the longest shadow, including maximum dimming of the outermost segments which are still lit.

9. If the dial indication is above 2.5 or below 0.2, set the Range Switch to the next higher or next lower range and readjust the Drive control for widest shadow.

10. Once the approximate null has been determined at this range with a setting between 0.2 and 2.5, turn the range switch one click clockwise. Then, relocate the null using the upper portion of the scale between 2.0 and 25.0.

11. Rotate the Sensitivity control clockwise to shorten the shadow, then again readjust the Drive control for maximum shadow. NOTE: If a long, well-defined shadow indication cannot be obtained, set the Function Switch to the 1KHZ position. If this does not correct the problem, use an external capacitor (refer to the paragraph describing the External Capacitor Terminal).

12. The conductance value of the solution is the dial reading times the multiplier which is in line with the pointer.

13. The conductivity of the solution is the conductance value in micromhos times the cell constant (K).

MAKING RESISTANCE MEASUREMENTS

Resistance measurements are made in much the same way as conductance measurements. The difference is that the operator uses the resistance ranges on the Range switch. The resistivity of the solution in ohms may be determined by dividing the indicated value by the cell constant (K).

SUBSTITUTION

The Model 31A provides better resolution than is indicated by the graduations on the dial scale, and accurate interpolation requires skill and judgment. If you need a more accurate reading than you can get by visual interpolation, a calibrated decade resistor may be substituted for the conductivity cell, and its dials manipulated to achieve the same null. Resistance can then be read directly from the decade resistor dials. Conductance is the reciprocal of that value. For resistivity or conductivity, apply the correction for the cell constant.

EXTERNAL CAPACITOR TERMINAL

Under some conditions it may be difficult to obtain a good maximum shadow on the indicator. This is due to phase shift in the bridge circuit caused by the conductivity cell's capacitive reactance. Although the accuracy of the bridge is not affected, there is a possibility of error in determining precisely where the maximum shadow occurs.

By adding a capacitor of the proper value to the bridge leg opposite the cell, the operator may correct the phase shift. The bridge can then be balanced correctly for a sharp, long shadow.

When it is necessary to use an external capacitor, the bridge frequency and dial reading should first be set for the longest shadow possible. The capacitance value to be used must be determined experimentally. The value may vary from several micro-farads at extremely low conductivities to several thousand micro-farads at high conductivities, depending on the cell constant and the electrolyte being measured.

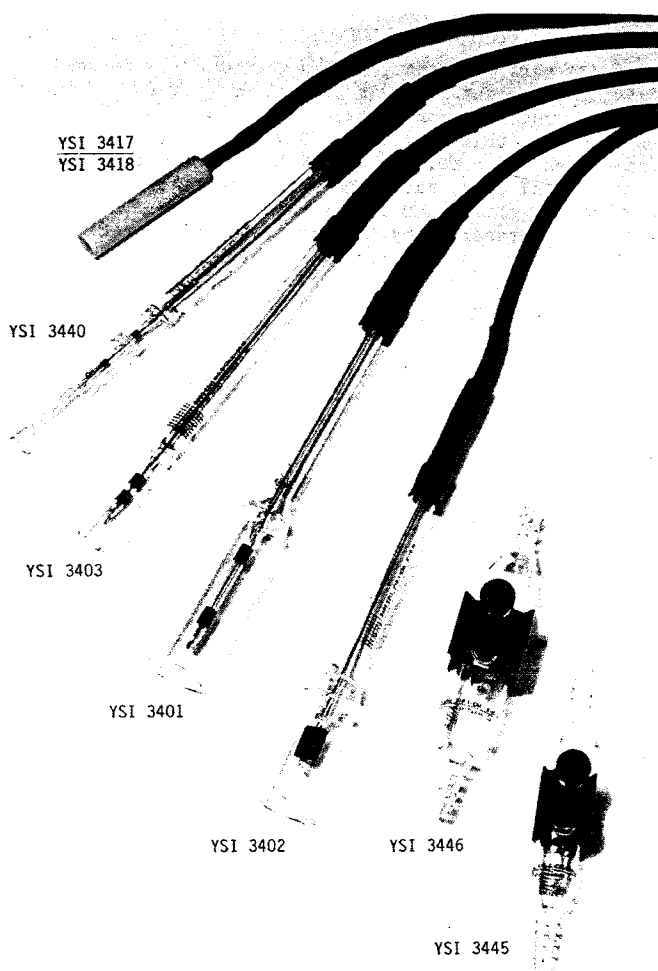

YSI 3400 SERIES CONDUCTIVITY CELLS

GENERAL DESCRIPTION

YSI offers several standard dip and flow-through conductivity cells, each utilizing platinum-iridium electrodes, except YSI 3418 which has platinumized nickel electrodes. These cells have the specifications listed in the chart below.

Part No.	Cell Constant	S.I. Cell Constant	Material	Overall Length	Max O.D.	Chamber I.D.	Chamber Depth
Dip Cells							
YSI 3401	K=1.0/cm	K=100/m	Fyrex 7740	7-1/2"	1"	13/16"	3"
YSI 3402	K=0.1/cm	K=10/m	Pyrex 7740	6-1/4"	1"	13/16"	2-1/16"
YSI 3403	K=1.0/cm	K=100/m	Pyrex 7740	7"	1/2"	3/8"	2"
YSI 3417	K=1.0/cm	K=100/m	ABS Plastic	5-3/4"	1/2"	3/8"	3/4"
YSI 3418	K=0.1/cm	K=10/m	ABS Plastic	6-1/4"	1/2"	3/8"	1-3/16"
YSI 3440	K=10.0/cm	K=1000/m	Pyrex 7740	8"	1/2"	5/64"	3-3/8"
Flow-Through Cells							
YSI 3445	K=1.0/cm	K=100/m	Pyrex 7740	5-3/4"	3/4"	3/8"	3"
YSI 3446	K=0.1/cm	K=10/m	Pyrex 7740	5-3/4"	1"	13/16"	3"

The nominal volumes of the flow-through cells are 15 ml for the YSI 3445 and 30 ml for the YSI 3446.

The cell part number and cell constant (K) are fired onto the Pyrex cells and are stamped on the plastic cells.

Cell constants are calibrated to $\pm 1\%$ accuracy against 0.01 demal KCl solution by means of a YSI transfer standard. (See Cell Calibration and Standard Solutions.)

CELL CONSTANT

The cell constant (K) is a factor which is used to determine resistivity or conductivity of a solution. In a geometrical sense this factor is, as its name implies, a true constant. However, the electrical properties of a cell do vary with electrolyte concentration and this variation should be taken into consideration if maximum accuracy is desired. Cell constant is determined by the physical configuration of the cell and its electrodes. Cells with constants of 1.0/cm or greater normally have small, widely spaced electrodes while cells with constants of 0.1/cm or less have larger electrodes which are closely spaced.

The user should decide which cell will be more useful based on the conductivities of the solutions in which he will be making measurements. Generally, K=1.0/cm cells will give good results with solutions between 20 and 20,000 micromhos. Values below or above this range are best measured with K=0.1/cm or K=10.0/cm cells. K=0.1/cm cells may be used for any value below 2000 micromhos, and K=10.0/cm cells for any value above 2,000 micromhos.

Conductivity is determined by multiplying the conductance measured in mhos or siemens by the appropriate cell constant (K), being careful to observe the dimensions of the constant.

CONDUCTIVITY CELL PRECAUTIONS

After selecting the proper cell, observe the following precautions in order to assure accurate, repeatable results:

1. The cell must be clean before making any measurement. (When working with substances having low conductivity, extraordinary cleanliness may be required.)
2. The cell should be suspended in the solution in such a way that the vent slots are submerged or in the case of flow-through cells, connected to a fluid line so that the cell is completely filled with the solution to be measured. The electrode chamber should be free of trapped air. (This may be accomplished by tilting the cell slightly and tapping the side.)
3. Dip cells should be at least 1/4 inch away from any other object, including the walls or bottom of the solution container.
4. Stirring or flow of solution is necessary for the highest accuracy in measurement, especially in low-conductivity solutions.
5. The presence of electrical fields and stray currents caused by stirrer motors, heaters, etc., can cause difficulties in obtaining good measurement results. The user should determine the effects of these and make the necessary corrections, either by shielding or by disconnecting during measurement those units which cause trouble.
6. The cell should always be handled carefully to decrease the possibility of breakage or loss of calibration accuracy.
7. The cell should never be transferred from one type of solution to another without having first been carefully rinsed.
8. Never store a dirty or contaminated cell.
9. In order to construct an easily calibrated, rugged cell, YSI solders the electrodes and supports in the 3440 Series Cells with gold solder. For this reason,

the cells should not be submerged in aqua regia or any solution which might etch or dissolve gold.

SPECIAL MEASUREMENT CONDITIONS

Small Sample Measurement

It is not always possible to immerse the conductivity cell in a solution for measurements. If the quantity of solution is not adequate for dipping a cell, a small sample may be used for assay. For this application, any 3400 Series Cell (except 3418) may be inverted and used as a sample holder (after sealing the vent slots in dip cells). Flow-through cells are particularly convenient for small sample measurement because the correction calculations described below are not necessary. Simply plug one end of the cell, fill, and measure.

The selection of a proper cell for small sample applications will depend upon the quantity of solution available and the conductivity of the solution. The 3401 cell (K=1.0cm) requires 15 ml, the 3402 cell (K=0.1/cm) requires 12 ml, the 3403 cell (K=1.0/cm) requires 3 ml, the 3417 cell (K=1.0/cm) requires 1 ml, the 3440 cell (K=10.0/cm) requires 3 ml. The 3445 and 3446 flow-through cells (K=1.0/cm and 0.1/cm) require 15 ml and 30 ml respectively.

The electrical conduction field within a sealed, inverted dip cell differs from the electrical field present when the cell is immersed in a solution. When used in this way, the conductance reading indicated must be multiplied by a corrected cell constant, which may be determined as follows:

1. Before sealing the vent slots, immerse the cell in room temperature tap water (or, preferably in a standard solution) and measure conductance.
2. Multiply by the cell constant to determine conductivity.
3. Seal the vent slots and fill the electrode chamber with some of the same solution and again measure conductance. Take care to ensure that neither solution temperature nor composition change during these steps.
4. Multiply by the cell constant to determine conductivity.
5. Divide the difference between the two conductivity determinations by the conductivity obtained in Step 4.
6. The result of Step 5 is a percent variation of cell constant. Add this variation to the constant marked on the cell. This result is the cell constant to use whenever the vent slots are closed.

Example: Cell constant (K)=1.0/cm

Step 1 Conductance = 1200 micromhos
Step 2 Conductivity = 1200 x 1.0/cm = 1200 micromhos/cm
Step 3 Conductance = 1000 micromhos
Step 4 Conductivity = 1000 x 1.0/cm = 1000 micromhos/cm
Step 5 (Difference = 200 micromhos/cm) divided by 1000 micromhos/cm = 0.20
Cell constant (K) with closed slots = 1.20/cm.

Reagent Grade Water Measurement:

When making measurements on reagent grade water or other substances having extremely low conductivity, it is recommended that a cell having a constant of 0.1/cm be used.

MAINTENANCE AND CALIBRATION OF CELLS

Cleaning and Storage

The single most important requirement for accurate and reproducible results in conductivity measurement is a clean cell. A dirty cell will contaminate the solution and cause the conductivity to change.

1. Any one of the foaming acid tile cleaners, such as Dow Chemical "Bathroom Cleaner," will clean the cell adequately. When a stronger cleaning preparation is required, use a solution of 1:1 isopropyl alcohol and 10 Normal HCl.

CAUTION: Cells should not be cleaned in aqua regia or in any solution known to etch platinum or gold.

2. Dip the cell into the solution, making certain it is submerged beyond the vent slots in the electrode chamber. Flow-through cells should be filled and agitated.

3. Agitate the solution for one or two minutes.

4. Remove the cell from the solution and rinse it with several changes of distilled or deionized water. Inspect the platinum black to see if replatinizing is required.

5. It is best to store conductivity cells in deionized water. Cells stored in water will require less frequent platinization. Any cell that has been stored dry should be soaked in distilled water for 24 hours before use.

Platinum Black Inspection

The electrodes of YSI 3400 Cells are coated with platinum black before calibration. This coating is extremely important to cell operation, especially in solutions of high conductivity.

The cell should be inspected periodically. If the coating appears to be thin or if it is flaking off the electrodes, the cell should be cleaned as noted above and the electrodes replatinized.

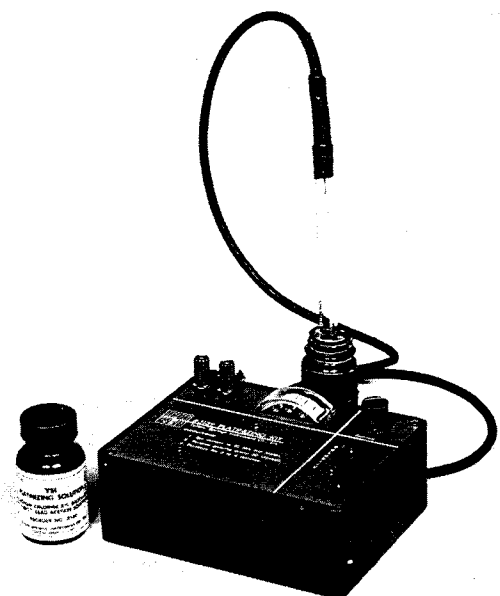

THE YSI 3139 PLATINIZING INSTRUMENT IN USE

Replatinizing

A YSI 3139 Platinizing Instrument and two-ounce bottles of YSI 3140 Platinizing Solution are available from your dealer.

Platinizing is accomplished as follows:

1. Place solution in the platinizing bottle. (Dip cells only.)

2. Connect the cell to the binding posts.

3. Place the cell in the solution with both electrodes submerged. For flow-through cells, plug end and fill the cell. Use of tubing and a small funnel will simplify this operation.

4. Adjust the current control for 50 mA indication.

5. Reverse polarity to the cell every 30 seconds until both electrodes are covered with a thin black layer. Do not over-platinize.

6. Remove the cell from the solution and disconnect it from the binding posts.

7. Return the platinizing solution to its bottle. It may be reused many times. Discard it only when it will no longer replatinize conductivity cells.

8. Rinse the electrodes in running tap water for about 15 minutes.

9. Rinse the cell in distilled or deionized water, and store or use.

Cell Calibration

The "cell constant" of a conductivity cell may vary slightly with the conductivity of the solution being measured. Calibration may also be affected by electrode fouling, replatinization, or by mechanical shock. A cell and meter can be calibrated together, as a system, with YSI 3160-3165 Conductivity Calibrator Solutions to an accuracy of approximately $\pm 0.25\%$ at 1000, 10,000 and 100,000 micromho/cm.

Part Number	Size	Conductivity at 25.00 degrees C
YSI 3160	Gallon	1000 micromho/cm $\pm 0.5\%$
YSI 3161	Quart	1000 micromho/cm $\pm 0.5\%$
YSI 3162	Gallon	10,000 micromho/cm $\pm 0.25\%$
YSI 3163	Quart	10,000 micromho/cm $\pm 0.25\%$
YSI 3164	Gallon	100,000 micromho/cm $\pm 0.25\%$
YSI 3165	Quart	100,000 micromho/cm $\pm 0.25\%$

Directions for calibration at other than 25 degrees C are included with the Conductivity Calibrator Solutions.

In calculating the cell constant in absolute terms, the uncertainty of the meter calibration must be added to the tolerance of the Conductivity Calibrator Solution.

CIRCUIT DESCRIPTION

The Model 31A circuit is an AC Wheatstone Bridge. Three utility circuits are provided to aid in operation of the bridge as a measurement device. The first circuit is a Wien Bridge oscillator which generates a user selected sine wave of either line frequency or 1000 Hertz to excite the bridge. The second is a null amplifier that detects and amplifies the bridge signal.

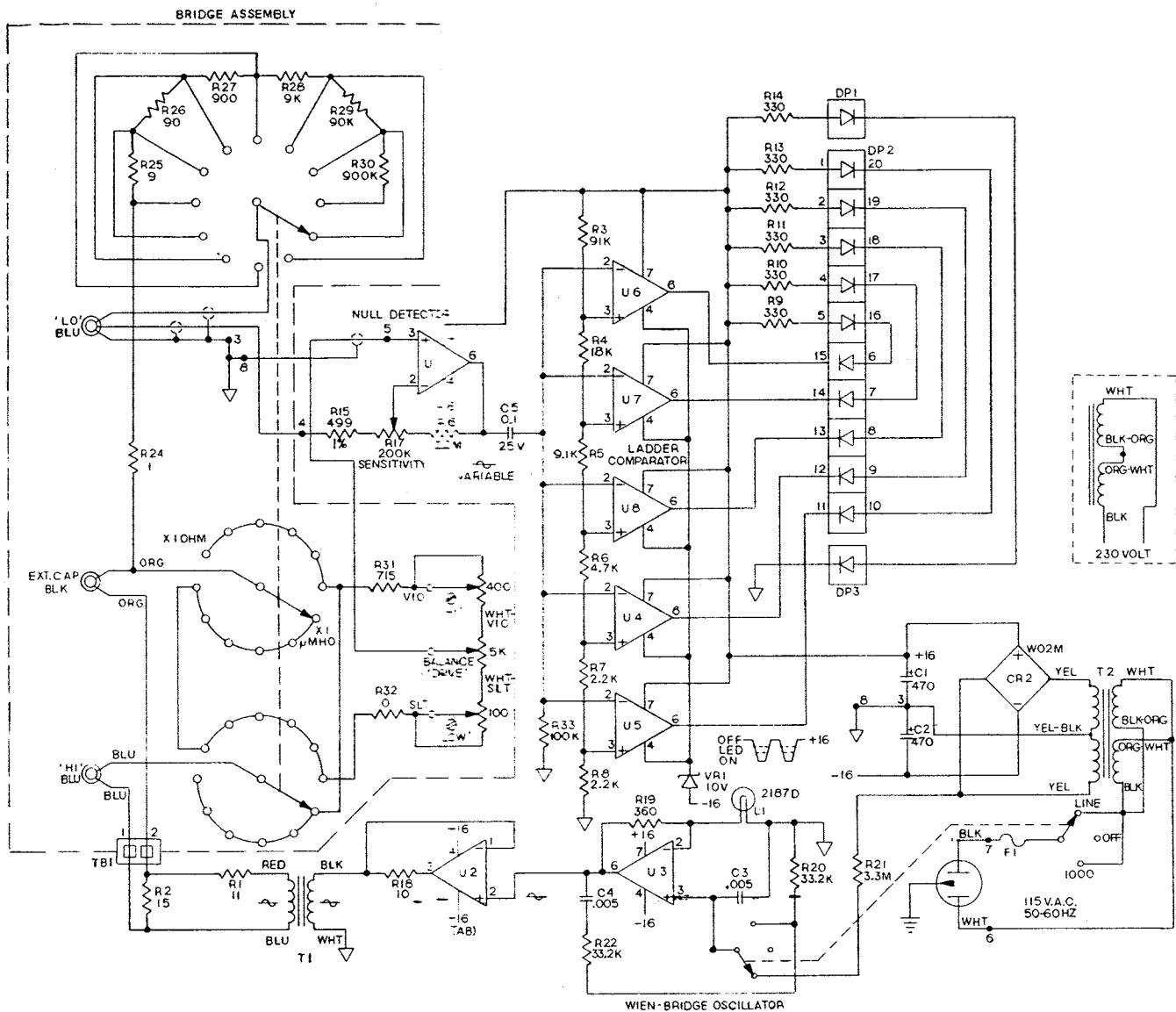

This schematic is representative,
and may differ slightly from the
circuit in your instrument.

NOTES:

- 1 Unless otherwise specified, resistance values are in ohms and capacitance values are in microfarads.
- 2 OP AMPS U1, U3, U4, U5, U6, U7 and U8 are EL081C
OP AMP U2 is μ A759U1C

FUSE 115V Line 1/8 Amp Slo Blow
(F1) 230V Line 1/16 Amp Slo Blow

SCHEMATIC

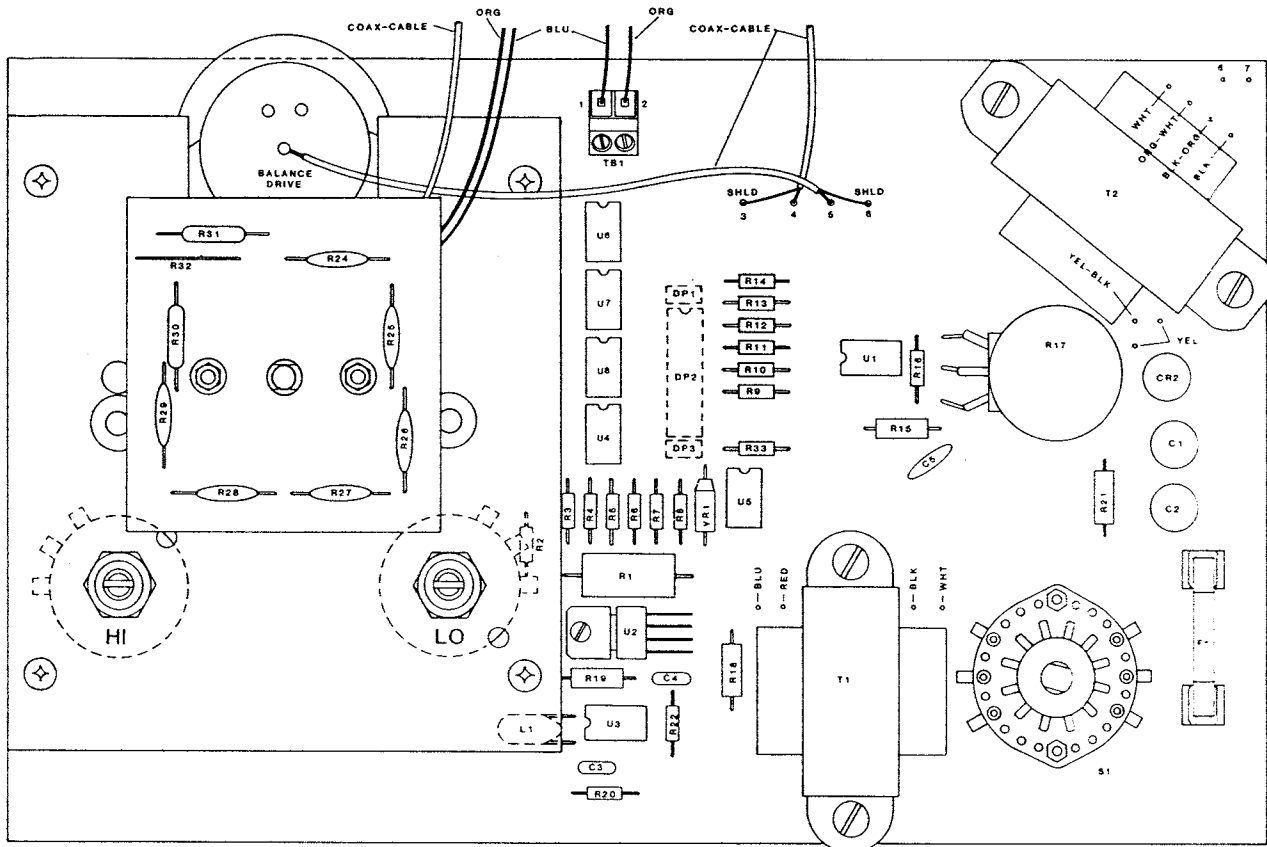

P.C. BOARD LAYOUT

The sensitivity control varies the circuit gain from 10 to 2000. The third circuit is a ladder-comparator with a binary weighted reference divider which controls the LED bar graph null indicator.

The oscillator uses a TL081C Operational Amplifier. A 2187-D subminiature lamp is used as a thermal control element to produce a low distortion sine wave. The thermal time constant of this element is several cycles long. As the oscillator signal amplitude increases, the lamp heats up causing its resistance to increase, which reduces the gain of the amplifier. A Fairchild uA759 op-amp buffer is used to drive the bridge transformer. An 11 ohm output resistor dampens parasitic oscillations caused by the inductive load of the bridge transformer. A resistive pad in the transformer secondary provides short circuit protection to the op-amp.

The null detector, also a TL081C op-amp, is an adjustable gain inverting amplifier. The amplified bridge signal is AC coupled to the ladder comparator.

The ladder comparator is composed of five op-amps, one TL081C and four similar sections in the TL084C package. Each section compares the signal from the null detector with a positive voltage from the reference string. The voltage for the reference string is the positive supply voltage. The steps on the string are binary weighted ratios of 1:1, 2:1, 4:1, 8:1 and 16:1. The output of each comparator drives a symmetrically positioned pair of LEDs on the bar graph. There is one extra set of LED segments at the

ends of the bar graph which are wired ON as a power indicator; they also frame the indicator WINDOW at the extreme ends of the null at maximum sensitivity.

The power supply in the Model 31A is a simple center tapped secondary with a diode bridge and two filter capacitors producing positive and negative 16 volt supplies for the op-amps.

CALIBRATION

The instrument was fully calibrated and tested at the factory before shipment. If the bridge assembly components are replaced or if the instrument has been in service for a long time, a calibration check is desirable. The YSI Product Service Department at the factory can provide calibration. Should it be impossible to return your instrument for this service, it may be calibrated by the following procedure.

CONTROL ASSEMBLY CALIBRATION

The control assembly includes the reference resistors and the null pot with its HI and LO adjust trims. The null pot is coupled to the dial plate through two 48-pitch gears held in mesh with an anti-backlash (idler) spring.

The first step in calibration is to obtain an accurate mechanical alignment of the dial-plate to the null pot through the gear train. This will require

disassembly of the instrument. You will need an ohmmeter resolving one ohm on the range from 48 to 58 ohms and a 1/16 inch Allen (hex) wrench.

1. Remove six screws to separate the white front panel from the gray dust cover.

2. Disconnect the wires attached to the binding posts marked LO and EXT CAP at the terminal block on the P.C. Board.

3. Attach ohmmeter set to its highest range between terminals 1 and 2 on the Balance Pot and observing the resistance, rotate the gears until the meter indicates an open circuit. Set meter to a range that will resolve a reading between 4850 and 5150 ohms. Move the meter leads to terminals 1 and 3. Check for a stable 5 digit reading. If the reading is unstable reverse the leads. Keep the resulting terminal 1 lead on terminal 1 hereafter. Record the reading and compute 0.0109387 times the resistance and record this value. This will be the first calibration value. Reconnect the ohmmeter to terminals 1 and 2 and set it to a range that will resolve 40 to 50 ohms.

4. Adjust DRIVE until the set screws on the center gear are accessible. Loosen both set screws until the gear is free to spin on the dial shaft.

5. Adjust DRIVE until the scale reads 0.2 under the index.

6. ONLY IF THE BRIDGE ASSEMBLY HAS BEEN DISASSEMBLED, disengage the gear set by lifting the null pot assembly against the spring. Then rotate the null pot gear to obtain a reading of less than 100 ohms. Remesh the gears.

7. Using the Allen wrench, rotate the center gear to obtain the computed calibration value. Carefully tighten the set screw as you maintain adjustment.

THIS IS A CRITICAL, DELICATE ADJUSTMENT.— The actual resistance obtained will affect the linearity of the assembly.

8. Rotate the dial assembly several turns of the DRIVE control and return to 0.2. Record the resistance between terminals 1 and 2 of the balance pot.
A = _____

9. Adjust DRIVE until 25 appears under the index. Record the resistance between terminals 1 and 2 of the balance pot.
B = _____

10. Record the resistance between terminals 1 and 3 of the null pot.
C = _____

11. These three resistances may be used to compute the initial settings of the HI and LO adjustment trims. The pots should be somewhere near mid-range.

$HI = [(35B - 10.2A) / 24.8] - C$
HI must be between 715 and 1115 ohms

Measure the resistance between null pot terminal 3 and the center end of R31. Adjust the HI trim to the value computed above.

$LO = (0.1 HI + 0.2C - 10.2A) / 10$
LO must be between 15 and 100 ohms

Measure the resistance between null pot terminal 1 and the wire jumper on the switch PC board. Adjust the LO trim to the value computed above.

THIS COMPLETES THE MECHANICAL ALIGNMENT OF THE CONTROL ASSEMBLY.

12. Reconnect the two wires to their respective binding posts. Connect to the binding posts a 5 or 6-dial decade resistor.

13. Adjust the decade resistor to 00.200. Set the instrument function switch to read the resistance on any scale appropriate to the decade resistor selected (200 ohms to 25K ohms is recommended). Apply power to the Model 31A. Null the bridge and observe the error, if any. DO NOT PERFORM ANY ADJUSTMENTS YET.

14. Adjust the decade resistor to 25.000 and null the bridge again. Observe the error, if any.

15. The error, if any, should be approximately equal in degrees of dial at both 00.200 and 25.000. This indicates that null pot alignment is within range and that the HI and LO trims are close.

16. Adjustments in Steps 13 and 14 interact; repeat them twice, each time correcting half the error, if any, using the HI and LO trims on the bridge assembly.

17. Turn off the instrument, unplug the power cord and reassemble the front panel assembly to the case.

CONDUCTIVITY SYSTEM ACCURACY CONSIDERATIONS

System accuracy, for conductivity determinations, is the sum of the errors contributed by the environment and the various components of the measurement setup. Included are:

- Instrument accuracy
- Cell-constant error
- Solution temperature offset
- Cell contamination (including air bubbles)
- Cell platinization problems
- Electrical noise
- Contact resistance
- Cable series resistance and shunt capacitances
- Cell series and shunt capacitances
- Galvanic effects and miscellaneous

Only the first three of these need be of major concern for typical measurements, although the user should also be careful to see that cells are clean and maintained in good condition at all times. Additional discussion of these and other factors affecting system accuracy is provided below.

Instrument Accuracy

Instrument error, worst case for this purpose, is the stated accuracy for the range being used. It should be noted that many instruments have different specifications for different ranges and that claims are sometimes misleading. For example, the YSI Models 31 and 31A have dial ranges which are greater than the effective measurement range for which an accuracy statement can be provided.

Cell-Constant Error

Some manufacturers provide cells to only a nominal cell-constant value (± 10 to 20%). It is then the user's responsibility to determine the actual cell constant for the range of concentration values in which the cell is to be used. Although YSI does much better than this (see below) there is really nothing wrong with the practice described. Conductivity is found by multiplying a measured conductance value by the cell

constant; if the constant is found to be, for example, 1.07/cm rather than 1.00/cm, it can be used with equal accuracy, if somewhat less convenience. Conductivity authorities also consider the cell constant to be non-linear and ASTM specifies different cells for different concentration ranges.

YSI cells are calibrated to within one percent of the stated cell constant at a single point and we consider these products to be usefully linear over most instrument ranges. We do, however, also recommend that $K=0.1/cm$ cells be used in measuring very low conductivity solutions and that $K=10.0/cm$ be used in measuring very high conductivity solutions. The cell constant can be calibrated to $\pm 0.35\%$ accuracy with YSI 3160-3165 Calibrator Solutions.

Temperature Error

The solution temperature error is the product of the temperature coefficient and the temperature offset from 25 degrees C, expressed as a percentage of the reading which would have been obtained at 25 degrees C. The error is not necessarily a linear function of temperature.

Automatic temperature compensation cannot totally eliminate this error but YSI instruments which offer this feature will limit it to 1% of full scale on the range being used, if the proper coefficient is dialed in.

Temperature measurement error is a problem for either automatic compensation or manual temperature correction.

Total Error

Considering only the above three factors, system accuracy under worst case conditions will be $\pm 3\%$, but considerably less if recommended and properly calibrated cells, instrument ranges and automatic temperature compensation are used. Additional errors, which can essentially be eliminated with proper handling, are described below.

Cell Contamination

This error source might usually be more properly described as one in which the cell is contaminating the solution being measured, often through carry-over from previous measurements. The instrument might be correctly reporting the conductivity seen but that reading does not accurately represent the value of the bulk solution. Errors will be most serious when measuring low conductivity solutions and can then be of an order of magnitude or more.

The user should carefully follow the cleaning instructions provided before attempting low conductivity measurements with a cell of unknown history or one which has been previously used in higher value solutions.

An entirely different form of contamination is sometimes seen as a buildup of foreign material directly on cell electrodes. While perhaps rare, examples have turned up where such deposits have markedly reduced the effectiveness of platinization, which in turn reduces the so-called double-layer capacitance and the electrical coupling to the solution being measured. The result is a lower conductance reading (see Cell Platinization Errors below).

Cell Platinization Errors

Most YSI instruments are quite forgiving of a cell which has begun to lose its electrode coating of platinum black. However significant errors can be introduced when measuring solutions having high conductivity values. The effect of poor platinization is a reduction of the apparent double-layer or series capacitance in the cell, which in turn appears as a frequency-dependent reactance which is difficult to balance in bridge instruments or to cancel completely with bi-polar drive approaches.

Instructions for electrode inspection and replatinization when necessary should be carefully followed before attempting critical measurements of any kind.

Electrical-Noise Errors

Electrical noise can be a problem in any measurement range, but will contribute the most error and be the most difficult to eliminate for the lowest conductance settings. The noise may be either line-conducted or radiated or both and therefore may require revised lead dress, grounding, shielding or all three. Often all that is necessary is to make sure that parallel leads are of equal length and twisted together and that line-powered instruments are properly grounded. Additional tips on electrical interference reduction will be found in most conductance instruction manuals.

Contact Resistance

It is perhaps only common sense to suggest that a good contact be made between cell leads and instrument terminals, but the magnitude of error that can result from a fraction of an ohm of contact resistance on the highest conductivity range is not always appreciated. Lugs should be clean and free of mechanical distortion. They should fit squarely on terminal posts which should be properly tightened. Leads should also be inspected to verify that no physical damage has occurred which might degrade electrical contact.

Cable Series Resistance and Shunt Capacitance

The short cables provided as a part of regular cell assemblies will introduce negligible error for most measurements. However, if longer cables are required or if extraordinary accuracy is necessary, special precautions and/or cable calibration may be prudent.

When working with solutions having very high conductivity values (more than 200 millimhos/cm), a cable resistance of a tenth of an ohm will introduce an error of 2% or more.

When working with solutions having very low conductivity values (less than 2 micromhos/cm) a cable capacitance of only 100 picofarads will produce errors of 0.3% or more on some instruments. Modern YSI forced-current models can accommodate shunt capacitance ten times greater than this, down to 1 micromho/cm conductivity, with no significant capacitance error. However caution is still advised when working on our lowest conductivity ranges with ultra-pure waters, etc.

Cell Series and Shunt Capacitances

Most commercial cells intended for laboratory use have negligible shunt capacitance, a few tens of pico-

F. Temperature Correction Data for Typical Solutions

1. Sodium Chloride* (NaCl)

Saturated solutions at all temps.

Concentration: 0.5 mole/liter		
°C	millimhos/cm	%/°C (to 25°C)
0	134.50	1.86
5	155.55	1.91
10	177.90	1.95
15	201.40	1.99
20	225.92	2.02
25	251.30	2.05
30	277.40	2.08

Concentration: 1 x 10 ⁻¹ mole/liter			Concentration: 1 x 10 ⁻² mole/liter		
°C	millimhos/cm	%/°C (to 25°C)	°C	millimhos/cm	%/°C (to 25°C)
0	5.77	1.83	0	.632	1.87
5	6.65	1.88	5	.731	1.92
10	7.58	1.92	10	.836	1.97
15	8.57	1.96	15	.948	2.01
20	9.60	1.99	20	1.064	2.05
25	10.66	2.02	25	1.186	2.09
30	11.75	2.04	30	1.312	2.12
35	12.86	2.06	35	1.442	2.16
37.5	13.42	2.07	37.5	1.508	2.17
40	13.99	2.08	40	1.575	2.19
45	15.14	2.10	45	1.711	2.21
50	16.30	2.12	50	1.850	2.24

Concentration: 1 x 10 ⁻³ mole/liter		
°C	millimhos/cm	%/°C (to 25°C)
0	.066	1.88
5	.076	1.93
10	.087	1.98
15	.099	2.02
20	.111	2.07
25	.124	2.11
30	.137	2.15
35	.151	2.19
37.5	.158	2.20
40	.165	2.22
45	.180	2.25
50	.195	2.29

2. Potassium Chloride** (KCl)

Concentration: 1 mole/liter			Concentration: 1 x 10 ⁻¹ mole/liter		
°C	millimhos/cm	%/°C (to 25°C)	°C	millimhos/cm	%/°C (to 25°C)
0	65.10	1.67	0	7.13	1.78
5	73.89	1.70	5	8.22	1.80
10	82.97	1.72	10	9.34	1.83
15	92.33	1.75	15	10.48	1.85
20	101.97	1.77	20	11.65	1.88
25	111.90	1.80	25	12.86	1.90
			30	14.10	1.93
			35	15.38	1.96
			37.5	16.04	1.98
			40	16.70	1.99
			45	18.05	2.02
			50	19.43	2.04

Concentration: 1 x 10 ⁻² mole/liter			Concentration: 1 x 10 ⁻³ mole/liter		
°C	millimhos/cm	%/°C (to 25°C)	°C	millimhos/cm	%/°C (to 25°C)
0	.773	1.81	0	.080	1.84
5	.892	1.84	5	.092	1.88
10	1.015	1.87	10	.105	1.92
15	1.143	1.90	15	.119	1.96
20	1.275	1.93	20	.133	1.99
25	1.412	1.96	25	.147	2.02
30	1.553	1.99	30	.162	2.05
35	1.697	2.02	35	.178	2.07
37.5	1.771	2.03	37.5	.186	2.08
40	1.845	2.05	40	.194	2.09
45	1.997	2.07	45	.210	2.11
50	2.151	2.09	50	.226	2.13

3. Lithium Chloride* (LiCl)

Concentration: 1 mole/liter			Concentration: 1 x 10 ⁻¹ mole/liter		
°C	millimhos/cm	%/°C (to 25°C)	°C	millimhos/cm	%/°C (to 25°C)
0	39.85	1.82	0	5.07	1.87
5	46.01	1.85	5	5.98	1.85
10	52.42	1.89	10	6.87	1.85
15	59.07	1.92	15	7.75	1.85
20	65.97	1.95	20	8.62	1.85
25	73.10	1.98	25	9.50	1.86
30	80.47	2.02	30	10.40	1.88
35	88.08	2.05	35	11.31	1.91
37.5	91.97	2.07	37.5	11.78	1.92
40	95.92	2.08	40	12.26	1.94
45	103.99	2.11	45	13.26	1.98
50	112.30	2.15	50	14.30	2.02

Concentration: 1 x 10 ⁻² mole/liter			Concentration: 1 x 10 ⁻³ mole/liter		
°C	millimhos/cm	%/°C (to 25°C)	°C	millimhos/cm	%/°C (to 25°C)
0	.567	1.88	0	.059	1.93
5	.659	1.92	5	.068	2.03
10	.755	1.96	10	.078	2.12
15	.856	2.00	15	.089	2.19
20	.961	2.04	20	.101	2.25
25	1.070	2.08	25	.114	2.28
30	1.183	2.12	30	.127	2.31
35	1.301	2.16	35	.140	2.32
37.5	1.362	2.18	37.5	.147	2.32
40	1.423	2.20	40	.154	2.31
45	1.549	2.24	45	.166	2.29
50	1.680	2.28	50	.178	2.25

4. Potassium Nitrate** (KNO₃)

Concentration: 1 x 10 ⁻¹ mole/liter			Concentration: 1 x 10 ⁻² mole/liter		
°C	millimhos/cm	%/°C (to 25°C)	°C	millimhos/cm	%/°C (to 25°C)
0	6.68	1.78	0	.756	1.77
5	7.71	1.79	5	.868	1.80
10	8.75	1.81	10	.984	1.83
15	9.81	1.83	15	1.105	1.86
20	10.90	1.85	20	1.229	1.88
25	12.01	1.87	25	1.357	1.90
30	13.15	1.90	30	1.488	1.93
35	14.32	1.92	35	1.622	1.95
37.5	14.92	1.94	37.5	1.690	1.96
40	15.52	1.95	40	1.759	1.97
45	16.75	1.97	45	1.898	1.99
50	18.00	2.00	50	2.040	2.01

5. Ammonium Chloride* (NH₄Cl)

Concentration: 1 mole/liter			Concentration: 1 x 10 ⁻¹ mole/liter		
°C	millimhos/cm	%/°C (to 25°C)	°C	millimhos/cm	%/°C (to 25°C)
0	64.10	1.60	0	6.96	1.82
5	74.36	1.53	5	7.98	1.88
10	83.77	1.45	10	9.09	1.93
15	92.35	1.37	15	10.27	1.97
20	100.10	1.29	20	11.50	2.00
25	107.00	1.21	25	12.78	2.03
			30	14.09	2.06
			35	15.43	2.07
			37.5	16.10	2.08
			40	16.78	2.08
			45	18.12	2.09
			50	19.450	2.09

Concentration: 1 x 10 ⁻² mole/liter			Concentration: 1 x 10 ⁻³ mole/liter		
°C	millimhos/cm	%/°C (to 25°C)	°C	millimhos/cm	%/°C (to 25°C)
0	.764	1.84	0	.078	1.88
5	.889	1.86	5	.092	1.90
10	1.015	1.86	10	.105	1.91
15	1.144	1.91	15	.119	1.93
20	1.277	1.94	20	.133	1.95
25	1.414	1.97	25	.148	1.98
30	1.557	2.02	30	.162	2.01
35	1.706	2.06	35	.178	2.04
37.5	1.782	2.08	37.5	.186	2.06
40	1.860	2.10	40	.194	2.07
45	2.020	2.14	45	.210	2.11
50	2.186	2.18	50	.227	2.15

*Charts developed by computer interpolation of data from CRC Handbook of Chemistry and Physics, 42nd Ed., p. 2606, The Chemical Rubber Company, Cleveland.

**Charts developed by computer interpolation of data from International Critical Tables, Vol. VI, pp. 229-253, McGraw Hill, N.Y.

farads at most. The capacitance between leads of long cables will generally be of much greater concern (see above). However, special cells having very low constants are sometimes constructed for experimental or industrial applications. For example, process-stream cells having constants of $K=0.001/\text{cm}$ are known, if not common. Such cells use many interleaved closely-spaced plates of relatively large surface area and therefore exhibit relatively large shunt capacitances.

Although it may be possible to "balance out" even such large shunt reactance effects, a better approach will be to calibrate the measurement for the particular concentration range of interest. Since these unusual cells are placed in service because of special conditions, it can be assumed that the nature of those conditions is understood well enough to also permit special in-situ calibration procedures.

We have already touched upon the series or "double-layer" capacitance effect in the discussion of platinization. It is desirable that this capacitance be as large as possible and platinization helps to achieve this. Indeed, for most measurements series capacitance is so large that its effects can be ignored. The value of this capacitance is not a constant, it varies with solution concentration among other things, but for a properly platinized commercial cell the value is reported to be in the hundreds or even thousands of microfarads. However, not all cells are equal and instruments differ in their abilities to accommodate lower values of capacitance without error.

For some work, cells with very high constants are desirable ($K=100/\text{cm}$ or above) and such cells are occasionally constructed as needed, sometimes of little more than a pair of parallel wires. In this case, the series capacitance will be too low for any range of accuracy. However, the practice is quite acceptable if special calibration procedures are used and the user recognizes that his equipment will now have very poor linearity.

Galvanic and Miscellaneous Effects

In addition to the error sources described above, there is yet another class of contributors that can be ignored for all but the most meticulous of laboratory measurements. Such errors are always small and are generally completely masked by the error budget for cell-constant calibration, instrument accuracy, etc. However, they do exist. Examples range from parasitic reactances associated with the solution container and its proximity to external objects to the minor galvanic effects resulting from oxide formation or deposition on electrodes. Only trial and error in the actual measurement environment can be suggested as an approach to reduce such errors.

If the reading does not change as the setup is "tweaked," errors due to such factors can be considered too small to see (lead reversal is one example of adjustments which might be tried).

WARRANTY

All YSI products are warranted for one year against defects in workmanship and materials when used for their intended purposes and maintained according to manufacturer's instructions. Damage due to accidents, misuse, tampering, or failure to perform prescribed maintenance is not covered. This warranty is limited to repair or replacement at no charge.

If Service Is Required

Contact the dealer from whom you bought the instrument.

Report the date of purchase, model, serial number, and the nature of the failure. If the repair is not covered by warranty, you will be notified of the charge for repair or replacement.

When shipping any instrument, be sure that it is properly packaged for complete protection.